

IAC-19-A7.3.11

## Low-frequency observations using high-altitude balloon experiments (LOBE)

Raj Thilak Rajan <sup>a,\*</sup>, Prem Sundaramoorthy <sup>a,b</sup>, C.J.C.Vertegaal <sup>b</sup>, Anton Montagne <sup>a</sup>, Visweswaran Karunanithi <sup>a,c</sup>, Maneesh K. Verma <sup>a</sup>, Mark Bentum <sup>b,d</sup>, Chris Verhoeven <sup>a</sup>

<sup>a</sup> *Department of Microelectronics, Delft University of Technology, Delft, The Netherlands*

<sup>b</sup> *Department of Electrical Engineering, Eindhoven University of Technology, The Netherlands*

<sup>c</sup> *Innovative Solutions in Space (ISIS), Delft, The Netherlands*

<sup>d</sup> *Netherlands institute for Radio Astronomy (ASTRON), Dwingeloo, The Netherlands*

\* Corresponding Author

### Abstract

The frequency range below 30 MHz remains one of the last unexplored frequency ranges in radio astronomy. However, Earth-based observations at these wavelengths are severely impeded, due to man-made radio frequency interference (RFI) and atmospheric opacity. To overcome this impediment, various space-based radio astronomy studies have been proposed in the past decade, notably the OLFAR (Orbiting low Frequency Antennas for Radio Astronomy) study, which proposed a satellite swarm for ultra-long wavelength observation. To realize this mission, various technological challenges of a satellite swarm are currently being addressed, particularly antenna design, navigation, communication, distributed processing, and overall system and mission design. Secondly, the RFI levels at various altitudes from Earth is currently unknown, which is a hindrance in general for radio astronomy. To this end, we propose the use of high-altitude ballooning experiments to validate OLFAR sub-systems in pseudo-representative conditions. Furthermore, these ballooning experiments will measure the RFI in the ultra-long wavelength spectrum at various altitudes from Earth. Our project is termed LOBE (Low-frequency observations using high-altitude Balloon Experiments), and in this paper, we present an overview of the science objectives, payload, and the technological and programmatic challenges of the LOBE project.

**Keywords:** high-altitude balloons, space-based radio astronomy, ultra-long wavelength observation, satellite swarms, array of balloons

### 1. Introduction

The past two decades have witnessed a renewed interest in low-frequency (LF) radio astronomy, driven by fundamental scientific questions, such as studying the dark ages, epoch of re-ionization and search for extra-terrestrial intelligence. However, terrestrial observations at low frequencies below 30 MHz are severely hampered by ionospheric distortion and by man-made radio frequency interference (RFI) [1], and hence the spectrum of 0.3-30 MHz remains one of the last unexplored spectrums. To circumvent these limitations, space-based radio astronomy arrays, such as OLFAR (Orbiting low-frequency antenna array) [2] have been investigated. Such futuristic radio telescopes, will consist of tens of single-antenna satellites, employing space-based interferometry to construct radio maps of the cosmos. One of the key challenges in this context is the validation of the various critical OLFAR technologies, and subsequently to increase the TRLs (technology readiness levels) of the respective systems. These fundamental challenges lie in the science antenna [3], the low noise

amplifier (LNA) design [4], space-based interferometry, localization [5], synchronization [6], inter-satellite communication [7] [8], Earth-based downlink architecture [9], distributed processing [10], system design and mission design of satellite swarms. One of the many challenges is to validate the various subsystem prototypes in quick time.

#### 1.1 Goal

To validate OLFAR sub-systems in pseudo-representative conditions, we propose the use of high-altitude ballooning experiments, which are an economical alternative to space-missions. Furthermore, these ballooning experiments will also measure the radio-frequency interference (RFI) at various altitudes from Earth, which is an impediment to ground-based radio astronomy [11]. These measurements will enable, for the first time, the construction of spatial-interference model for LF interference at high-altitudes. The project is termed LOBE (Low-frequency observations using high-altitude Balloon Experiments), which offers a quick and affordable setup to measure and characterize various

subsystems including the LF science payloads, both electrically and structurally, and in addition enables RFI monitoring at high-altitudes in a harsh environment. In this paper, we present an overview of the science objectives, payload, and the technological and programmatic challenges of the LOBE project. In the following Section 2, we briefly discuss high altitude environments, in Section 3 we present the LOBE mission, followed by an overview of the LOBE payload design in Section 4, and finally concluding with a brief summary.

## 2. High altitude environments

The key environmental attributes that make high altitude ballooning experiments challenging are the temperature excursions and wind velocities. The atmosphere is a dynamic medium with both time and space variability on a scale that ranges from thousands of kilometers to tens of meters [12]. Atmospheric attributes such as wind speeds are a complex function driven by multiple inputs such as gravity waves and planetary waves as shown in Figure 1.

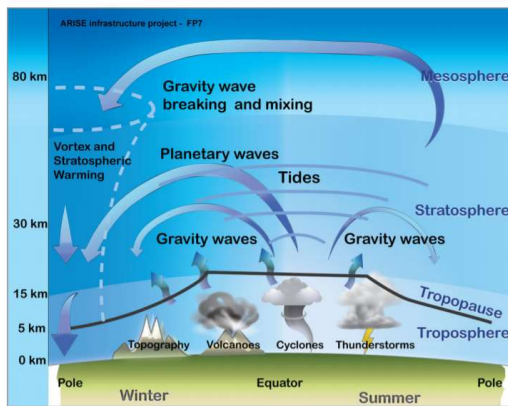

Figure 1: Schematic diagram of the atmospheric dynamic processes in the Earth's atmosphere. Reproduced from [12].

Many atmospheric models such as the International Standard Atmosphere (ISA) and International Civil Aviation Organization (ICAO) ISA are representative models to depict a hypothetical standard day and are biased by localized weather conditions. The ISA is based on a definite temperature distribution with altitude [13] as shown in Figure 2. However, there can be considerable day to day variations from this profile depending on location, season and time of day. A typical wind speed profile is shown in Figure 3, highlighting the seasonal and geographical variations that can be expected. However, non-standard days at different locations need to be modelled by adding location and time specific data. Therefore, there is considerable uncertainty in the prediction of parameters like wind and temperature.

The European Centre for Medium-Range Weather Forecasts (ECMWF) is a research institute and an operational service that provides global numerical weather predictions [14]. The ARISE (Atmospheric dynamics Research Infrastructure in Europe) project provides recent results on the challenges and methods involved in predicting atmosphere characteristics with quantified uncertainties [15].

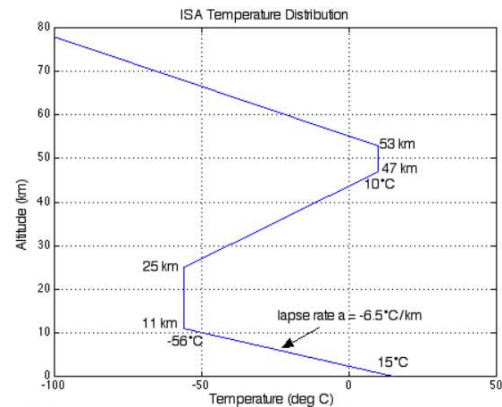

Figure 2: Temperature as a function of altitude. Reproduce from [13].

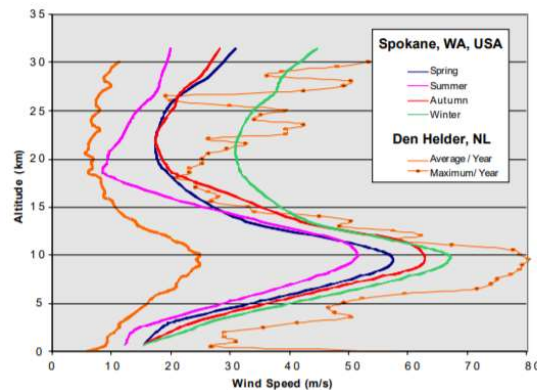

Figure 3: Typical Profiles of average wind speed versus altitude at different locations and different seasons. Figure reproduced from [16]

## 3. LOBE Project

The aim of the LOBE project is to develop, construct and experimentally verify an instrument for mapping the radio environment in the 0.3-80 MHz frequency range. This instrument should fit in a high-altitude balloon, which will measure the spectrum up to 50 km from the surface of Earth.

### 1.1 High-altitude balloons

There are various balloon types which can be used for the LOBE project, e.g., Totex, Latex and Plastic zero-pressure balloons [17]. Totex balloons are the most reliable, however are expensive, and have a significant lead time for design and construction. On the other hand, in case of Latex balloons, the burst altitude cannot be accurately predicted, and the payload can land in an undesirable location leading to difficulties in safe payload recovery. Other disadvantages are a short flight time of 2-3 hours (ascent and descent), low payload capacity (~5kg) and launch instability for the deployed antennas. Therefore, we propose the use of a plastic zero-pressure balloon, which typically has the capability to carry heavy (~40kg) payloads to the desired ceiling altitude.

The balloon and the onboard LOBE payload can be made to float for about 2 to 5 hours depending on the wind speed and direction resulting in a long flight time. The payload will be brought down at a safe landing site enabling the payload recovery in good shape, which is crucial for the LOBE experiment. We will use standard off-the-shelf balloon-support communications for which suitable interference mitigation filters have to be incorporated in the LOBE payload.

### 1.2 Project phases

LOBE will be executed in 2 parts. In Phase 1, a single plastic zero-pressure balloon will be deployed, carrying a science payload weighing less than 5 kg, to reach altitudes of up to 30 km, with a mission lifetime of 3-4 hours. The science payload will monitor the environment for low frequency radio astronomy on various altitudes. This includes determining the RFI levels for various heights with respect to the Earth surface as well as looking at the impact of the ionosphere by looking at extra-terrestrial signals. The science payload will comprise of a LF antenna and custom designed LF front-end for observing the frequency band of 0.3-80 MHz, which is followed by a digital system for sampling, processing and data storage.

In Phase 2, multiple balloons will be launched and crucial OLFAR technologies will be validated in harsh environments. These include, for example, the wireless clock synchronization between balloons, relative localization and orientation estimation in 3-D space, inter-satellite communication architectures, distributed interferometry, evaluate cooperative algorithms, and broadly challenges of distributed systems in 3D space.

The basic scheme of the LOBE payload is straightforward, and is illustrated in Figure 4. The science antenna may comprise of 3 orthogonal elements, which will be in deployed condition for the balloon mission. Measurements with three antennas will assure the reception of signals from all directions. It is possible to observe at lower frequency, but with reduces sensitivity. The three analogue signals will be digitized and the raw data will be stored. Since the length of the experiment is limited and the payload will come back to the Earth surface, the data processing will be done off-line. Meanwhile, the aim of the on-board digitization is only to store the signal strength observed in each frequency channel, and not to decode the signal itself. A list of top-level specifications is given in Table 1.

Furthermore, since we only intend to detect signal strength at various altitudes, we will not demodulate or decode any signals in our measurement spectrum of interest. In addition, if necessary, we aim to design/re-configure our system to ignore any regulation-sensitive frequency band within the spectrum of interest.

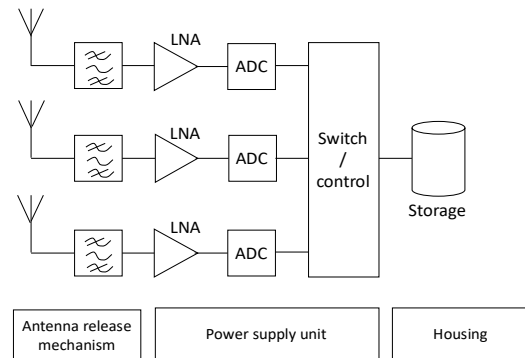

Figure 4: An illustration of the LOBE payload

Table 1: A list of requirements for LOBE payload

	Value
Frequency range	0.3-80MHz
Number of frequency bins	79700
Spectral resolution	1kHz
Recording time	Up to 4 hours
Dynamic range	120dB
Payload mass	5 kg (max)
Data rate	1Mbps
Total data volume	35 GB

## 4. LOBE Payload

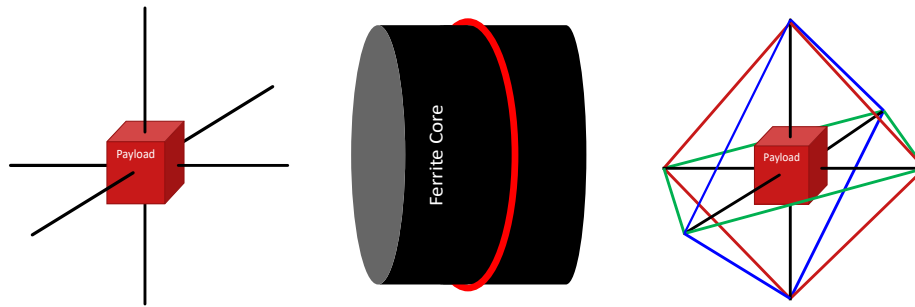

Figure 5: Tripole setup (left), Loop Antenna including Ferrite Core (middle) and Vector Antenna (right) where the three colors represent the different loop antennas.

### 1.1 Antennas

One of the key aspects of the payload is the antenna design, which must detect and monitor the man-made radio frequency interference (RFI). To achieve this goal, the antenna should have multiple properties. The foremost requirement, is the high antenna sensitivity at frequencies between 0.3-80 MHz. Secondly, the radiation pattern of such an antenna should be hemispherical towards ground as we want to avoid to also receive signals from space.

The most commonly used antenna design for achieving these goals is monopole/dipole/tripole as seen in Figure 5. The antenna wires typically have an omnidirectional radiation pattern and are resonant at the half wavelength point. The disadvantage however, is that they offer narrow bandwidth around the center frequency. The Netherlands China Low Frequency Explorer (NCLE) is a LF payload which is presently aboard the Change-4 mission, observing the cosmos at frequencies below 30MHz, which uses a tripole setup with three monopoles each 5m in length [18].

In earlier work different antenna types have also been investigated for their comparable application related to radio astronomy [3] [19], where a loop antenna was researched as shown in Figure 5. Here, it was concluded that for a single 1 turn loop antenna usable at 1 and 10 MHz a 10.7 and 7.6 cm diameter loop antenna, respectively, was needed. However, due to the required weight of the ferrite rods, which act as a low loss magnetic, in excess of 181 and 65 kg it was deemed impractical.

A different approach using a log periodic structure such as used for the SKA-LOW [20], will lead to mechanical issues due to its size and structure and will act comparable to a short dipole at the frequencies of interest. Another option is the use of an helical antenna, which as an electrically small antenna will also work comparably to an monopole/dipole. However, it is circular polarized

and the design of such antenna in its dual polarized equivalent is more difficult.

Finally, the vector antenna is also discussed as presented in [21] and visualized in Figure 5, where it was designed for low frequency radio astronomy in space. A vector antenna samples both the E-field and the H-field at a single location in space. The structure consists of three electric dipole and three magnetic loop elements in an orthogonal setup. The main advantage is the ability to obtain full polarization information. However, it requires more advanced processing and will increase the weight and mechanical complexity of the system. Furthermore, no formal results have been presented yet.

For OLFAR, research is also being done into inflatable antennas as they allow for packing a large and low weight antenna into a small volume [22]. Although inflatable antennas show promising results for spaceborne applications, it will not be suitable due mechanical drag.

In conclusion it is chosen that a tripole, given its proven capability and simple design, is recommended for the LOBE project. The tripole will use a voltage sampler with a high input impedance low noise amplifier (LNA) to avoid frequency dependent behavior. Another option would be the use of multiple bands, each having a separate LNA.

We are considering antenna lengths (tip-to-tip) of 10m, 7.5m, 5m, 2.5m and 1m. The weight of a cross-dipole of 10m (tip-tip) copper antennas, having a diameter of 7.5mm is already 8 kg. However, the weight can be controlled by using composite materials which can be filled or covered with conductive material to lower the weight, which will allow for the third antenna. The mechanical integrity of the antenna structure is crucial, which should not collapse at higher altitudes and strong winds. Such scenarios can be avoided, by connecting the antenna tips to each other and to the balloon itself, and thereby mitigating undesired forces. The mechanical

stability of the payload is one of the key challenges currently investigated in the LOBE project.

### 1.2 Antenna front-end

The front-end is essentially the antenna followed by an integrating transimpedance amplifier, which can be shown to offer the best possible intermodulation-free dynamic range (IMFDR) in the desired frequency band. The frequency response of such a configuration is not perfectly flat, but deviations from this flatness are fully predictable and can be compensated for using post-processing operations in the digital backend. The design consideration for the proposed amplifier are extensively described in [23], and for low-noise design and analysis techniques the reader is referred to [24].

### 1.3 Digital backend

The signals will be digitized by on-board Analog to Digital converter (ADC). In the ADC the signals from the possible 3 antennas configuration will be digitized. A 16-bit ADC is foreseen, which suffices our requirement. The raw data stream will be stored. If we assume a 4-hour mission, 80,000 frequency bins (of 1 kHz each), 100ms integration, this requires: ~35 GB of data storage (80,000 x 2 bytes x 10 x 60 x 60 x 4 x 3), which can be stored in an onboard USB/SD card. In addition to the science data, the time-stamp of observation (i.e., clock information), position, orientation, and other environmental parameters such as temperature, pressure and available meta-data will be stored. The entire setup can be implemented using an off-the-shelf Field programmable gain array (FPGA) board, or a Software-defined Radio (SDR).

### 1.4 Post processing

The off-line data processing includes several dedicated science modes. These modes perform fast Fourier transforms (FFTs) to create average radio spectra for which spectral resolution and frequency range can be selected, allow triggering on transient radio events, or allow to retrieve Direction of Arrival (DOA) information using beam forming and other techniques.

## 5. Conclusions

The LOBE project is a testbed for validating various subsystems for satellite swarms, particularly for space-based interferometry missions such as OLFAR. In addition, LOBE aims to map the RFI environment at ultra-long wavelength at altitudes up to 50 kms. In this paper, we briefly discussed the concept of LOBE and the various technological and programmatic challenges of the LOBE project.

## Acknowledgements

This project is funded by the NWO-NSO PIPP-OLFAR program. We would like to thank our team members Samaneh Babayan, Prabhav Manchanda, and Harald Luiks for discussions.

## References

- [1] R. T. Rajan, A.-J. Boonstra, M. Bentum, M. Klein-Wolt, F. Belien, M. Arts, N. Saks and A.-J. and van der Veen, "Space-based aperture array for ultra-long wavelength radio astronomy. Experimental Astronomy, 41(1-2), pp.271-306.," *Experimental Astronomy*, vol. 41, no. 1-2, pp. 271-306, 2016.
- [2] R. T. Rajan, S. Engelen, M. Bentum and C. Verhoeven, "Orbiting Low Frequency Array for radio astronomy," in *IEEE Aerospace*, 2011.
- [3] M. J. Arts, E. van der Wal and A. J. Boonstra, "Antenna Concepts for a Space-Based Low-Frequency Radio Telescope," in *32th ESA Antenna Workshop on Antennas for Space Applications*, Noordwijk, 2009.
- [4] S. Babayan-Mashhadi, R. T. Rajan, M. Bentum and C. Verhoeven, "A Low-Power CMOS Low Noise Amplifier for Space-based Low-frequency Radio Astronomy," in *70th International Astronautical Congress (IAC)*, Washington D.C., 2019.
- [5] R. T. Rajan, G. Leus and A.-J. { . d. Veen, "Relative kinematics of an anchorless network," *Signal processing*, vol. 157, pp. 266-279, 2019.
- [6] R. T. Rajan and A.-J. v. d. Veen, "Joint Ranging and Synchronization for an Anchorless Network of Mobile Nodes," *IEEE Transactions on Signal Processing*, vol. 63, no. 8, pp. 1925--1940, 2015.
- [7] A. Budianu, R. T. Rajan, S. Engelen, A. Meijerink, C. Verhoeven and M. Bentum, "OLFAR: Adaptive topology for satellite swarms," in *International Astronautical Congress*, Cape Town, 2011.
- [8] V. Karunanithi, R. T. Rajan, P. Sundaramoorthy, M. K. Verma, C. Verhoeven, M. Bentum and E. W. McCune, "High Data-Rate Inter-Satellite Link (ISL) For Space-Based Interferometry," in *70th International Astronautical Congress (IAC)*, Washington D.C., 2019.

- [9] A. Budianu, A. Meijerink and M. Bentum, "Swarm-to-Earth communication in OLFAR," *Acta Astronautica*, vol. 107, pp. 14-19, 2015.
- [10] R. T. Rajan, M. Bentum, Boonstra, A. Gunst and A.-J. Boonstra, "Distributed correlators for interferometry in space," in *IEEE Aerospace Conference*, 2013.
- [11] M. Bentum, A.-J. Boonstra, W. Horlings and P. van Vugt, "The RFI situation for a space-based low-frequency radio astronomy instrument," in *IEEE Aerospace Conference*, 2016.
- [12] E. Blanc, L. Ceranna, A. Hauchecorne, A. Charlton-Perez, E. Marchetti, L. G. Evers, T. Kvaerna, J. Lastovicka, L. Eliasson, N. B. Crosby and others, "Toward an Improved Representation of Middle Atmospheric Dynamics Thanks to the ARISE Project," *Surv Geophys*, vol. 39, pp. 171-225, 2018.
- [13] Ohio University, "Hot Air Balloons," [Online]. Available: <https://www.ohio.edu/mechanical/programmin g/balloon/balloon.html>. [Accessed 30 09 2019].
- [14] "European Centre for Medium-Range Weather Forecasts," [Online]. Available: <https://www.ecmwf.int/en/about>. [Accessed 30 09 2019].
- [15] "ARISE results," [Online]. Available: <http://arise-project.eu/arise-results.php>. [Accessed 30 09 2019].
- [16] M. Hepperle, A. Ruiz-León, H. Runge and J. Horwath, "HALE Platforms - A Feasibility Study," Report of the Institute of Aerodynamics and Flow Technology, 2008.
- [17] J. C. Ego, "Performance of two types of meteorological balloons in upper air soundings in a tropical region".
- [18] D. S. Prinsloo et al., "EMI modelling of an 80 kHz to 80 MHz wideband antenna and low-noise amplifier for radio astronomy in space," in *12th European Conference on Antennas and Propagation (EuCAP)*, 2018.
- [19] L. Chen, A. Aminaei, L. I. Gurvits, M. K. Wolt, H. R. Pourshaghghi, Y. Yan and H. Falcke, "Antenna design and implementation for the future space Ultra-Long wavelength radio telescope," *Experimental Astronomy*, vol. 45, p. 231–253, March 2018.
- [20] E. d. L. Acedo, N. Razavi-Ghods, N. Troop, N. Drought and A. Faulkner, "SKALA, a log-periodic array antenna for the SKA-low instrument: design, simulations, tests and system considerations," *Experimental Astronomy*, vol. 39, no. 3, pp. 567-594, July 2015.
- [21] M. Knapp, F. Robey, R. Volz, F. Lind, A. Fenn, A. Morris, M. Silver, S. Klein and S. Seager, "Vector antenna and maximum likelihood imaging for radio astronomy," in *2016 IEEE Aerospace Conference*, Big Sky, MT, 2016.
- [22] C. J. C. Vertegaal and M. J. Bentum, "Feasibility Study of Inflatable Antennas as Observational Antenna for Ultra Low Frequency CubeSat Applications," in *IEEE Aerospace Conference [Submitted]*, Big Sky, MT, 2020.
- [23] A. J. M. Montagne, "Design of Active Antennas for the VLF-HF band," *In preparation*, 2019.
- [24] A. J. M. Montagne, *Structured Electronic Design*, Delft: Delft Academic Press / VSSD, 2018.