

TIME-DOMAIN CHANNEL SHORTENING AND EQUALIZATION OF OFDM OVER DOUBLY-SELECTIVE CHANNELS*

Imad Barhumi^{1†}, Geert Leus², Marc Moonen¹

¹K.U.Leuven-ESAT/SCD-SISTA
Kasteelpark Arenberg 10
B-3001 Heverlee, Belgium
{imad.barhumi,marc.moonen}@esat.kuleuven.ac.be

²T.U.Delft-EE Department
Mekelweg 4
2628CD Delft, The Netherlands
leus@cobalt.et.tudelft.nl

ABSTRACT

In this paper, we discuss time-domain equalization of OFDM over doubly-selective channels. We consider the most general case, where the channel delay spread is larger than the cyclic prefix (CP), which results into inter-block interference (IBI). IBI in conjunction with the Doppler effect destroys the orthogonality between subcarriers and hence, results in intercarrier interference (ICI). The time-domain equalizer (TEQ) is assumed to be a time-varying finite impulse response (TV FIR). The purpose of the TEQ is to convert the doubly-selective channel into a purely frequency-selective channel whose delay spread fits within the CP. In other words, the purpose of the TEQ is to restore orthogonality between subcarriers in the OFDM system.

1. INTRODUCTION

Orthogonal Frequency Division Multiplexing (OFDM) has attracted a lot of attention, due to its simple implementation and robustness against frequency-selective channels. However, in doubly-selective channels, the time variation of the channel over an OFDM block destroys the orthogonality between the subcarriers. In addition to this, inter-block interference (IBI) arises when the channel delay spread is larger than the cyclic prefix (CP). IBI in conjunction with the Doppler effect results in severe intercarrier interference (ICI).

Different approaches for reducing ICI have been proposed, including frequency-domain equalization and or time-domain windowing. In [1, 2] the authors propose matched-filter, least-squares (LS) and minimum mean-square error (MMSE) receivers incorporating all subcarriers. Receivers considering the dominant adjacent subcarriers have been presented in [3]. For multiple-input multiple-output (MIMO) OFDM over doubly-selective channels, a frequency-domain ICI mitigation technique is proposed in [4].

*This research work was carried out at the ESAT laboratory of the Katholieke Universiteit Leuven, in the frame of the Belgian State, Prime Minister's Office - Federal Office for Scientific, Technical and Cultural Affairs - Interuniversity Poles of Attraction Programme (2002-2007) - IUAP P5/22 ('Dynamical Systems and Control: Computation, Identification and Modeling') and P5/11 ('Mobile multimedia communication systems and networks'), the Concerted Research Action GOA-MEFISTO-666 (Mathematical Engineering for Information and Communication Systems Technology) of the Flemish Government, and Research Project FWO nr.G.0196.02 ('Design of efficient communication techniques for wireless time-dispersive multi-user MIMO systems'). The scientific responsibility is assumed by its authors.

[†]Partly supported by the Palestinian European Academic Cooperation in Education (PEACE) Programme.

A time-domain windowing (linear pre-processing) approach to restrict ICI support in conjunction with iterative MMSE estimation is presented in [5]. However, all of the above mentioned works, assume the channel delay spread fits within the CP, and hence, no IBI is present. Moreover, these works assume perfect knowledge of the TV channel at the receiver, which is rather difficult if not impossible to obtain. In this work we approximate the TV channel using the basis expansion model (BEM). We assume only the BEM coefficients are known at the receiver which is more realistic and easier to obtain.

A time-invariant (TIV) FIR TEQ [6] has been used to shorten a purely frequency-selective channel when its delay spread is larger than the CP. In this paper, we assume the doubly-selective channel to have a delay spread larger than the CP. A TV FIR TEQ is applied to convert the doubly-selective channel into a purely frequency-selective channel whose delay spread fits within the CP. The TV TEQ in conjunction with a 1-tap frequency-domain equalizer then allows us to estimate the QAM transmitted symbols.

Notation: We use upper (lower) bold face letters to denote matrices (column vectors). Superscripts $*$, T , and H represent conjugate, transpose, and Hermitian, respectively. We denote the Kronecker delta as $\delta[n]$. We denote the $N \times N$ identity matrix as \mathbf{I}_N and the $M \times N$ all-zero matrix as $\mathbf{0}_{M \times N}$. Finally, $\text{diag}\{\mathbf{x}\}$ denotes the diagonal matrix with \mathbf{x} on the diagonal.

2. SYSTEM MODEL

We assume a single-input multiple-output (SIMO) OFDM system with N_r receive antennas. At the transmitter, the conventional OFDM modulation is applied, i.e., the incoming bit sequence is parsed into blocks of N frequency-domain QAM symbols. Each block is then transformed into a time-domain transmitted sequence using an N -point IFFT. A cyclic prefix (CP) of length ν is inserted at the head of each block. The time-domain blocks are then serially transmitted over a multipath fading channel. The channel is assumed to be time-varying (TV). Focusing only on the baseband-equivalent description, the received signal at the r th receive antenna is given by:

$$\mathbf{y}^{(r)}[n] = \sum_{\theta=-\infty}^{\infty} g^{(r)}[n; \theta] x[n - \theta] + \eta^{(r)}[n], \quad (1)$$

where $g^{(r)}[n; \theta]$ is the discrete-time baseband-equivalent of the doubly-selective channel from the transmitter to the r th receive antenna, which consists of the transmit filter, receive filter and the time-varying physical channel. $\eta^{(r)}[n]$ is the baseband-equivalent

filtered additive noise at the r th receive antenna and $x[n]$ is the discrete time-domain sequence transmitted at a symbol rate of $1/T$ symbols per second. Suppose $S_k[i]$ is the QAM symbol transmitted on the k th subcarrier ($k \in \{0, \dots, N-1\}$, N is the total number of subcarriers in the OFDM block) of the i th OFDM block. Then $x[n]$ can be written as:

$$x[n] = \frac{1}{\sqrt{N}} \sum_{k=0}^{N-1} S_k[i] e^{j2\pi(m-\nu)k/N},$$

where $i = \lfloor n/(N+\nu) \rfloor$ and $m = n - i(N+\nu)$. Note that this description includes the transmission of a CP of length ν .

In this paper we use a basis expansion model (BEM) to model the TV channel [7, 8]. In this BEM, the doubly-selective channel $g^{(r)}[n; \theta]$ is modeled as an FIR filter where the taps are expressed as a superposition of complex exponential basis functions with frequencies on a discrete grid. Assuming $g^{(r)}[n; \theta] = 0$ for $\theta \notin \{0, \dots, L+1\}$, each channel $g^{(r)}[n; \theta]$ can be modeled for $n \in \{i(N+\nu) + \nu - L', \dots, (i+1)(N+\nu) - 1\}$ (L' to be defined later) by a BEM:

$$h^{(r)}[n; \theta] = \sum_{l=0}^L \delta[\theta - l] \sum_{q=-Q/2}^{Q/2} h_{q,l}^{(r)}[i] e^{j2\pi qn/K}, \quad (2)$$

where Q and K should be selected such that $Q/(KT) \geq 2f_{\max}$, with f_{\max} the maximum Doppler spread of all channels.

In this expansion model, L represents the delay-spread (expressed in multiples of T , the delay resolution of the model), and $Q/2$ represents the Doppler-spread (expressed in multiples of $1/(KT)$, the Doppler resolution of the model). Note that the coefficients $h_{q,l}^{(r)}[i]$ remain invariant over a period of length $(N+L')T$, and may change from block to block.

Substituting (2) in (1), the received sample sequence at the r th receive antenna can be written as:

$$y^{(r)}[n] = \sum_{l=0}^L \sum_{q=-Q/2}^{Q/2} e^{j2\pi qn/K} h_{q,l}^{(r)}[i] x[n-l] + \eta^{(r)}[n]. \quad (3)$$

3. TIME-DOMAIN EQUALIZATION

In this section we introduce time-domain equalization for OFDM systems over doubly-selective channels. We assume the most general case, where the TV channel order is larger than the CP. The purpose of the TEQ is to convert the doubly-selective channel into a frequency-selective channel with a delay spread that fits within the CP. At the r th receive antenna, we apply a TV FIR TEQ denoted by $w^{(r)}[n; \theta]$ to convert the doubly-selective channel of order $L > \nu$ and $f_{\max} \neq 0$ into a target impulse response (TIR) $b[\theta]$ that is purely frequency-selective with order $L'' \leq \nu$ and $f_{\max} = 0$. As shown in Figure 1, we require to design a TV FIR TEQ and TIR such that the difference term $e[n]$ is minimized in the mean square sense subject to some decision delay d .

The output of the TV FIR TEQ at the r th receive antenna, subject to some decision delay d , can be written as:

$$z^{(r)}[n-d] = \sum_{\theta=-\infty}^{\infty} w^{(r)}[n; \theta] y^{(r)}[n-\theta]. \quad (4)$$

Since we approximate the doubly-selective channel using the BEM, it is convenient also to model the TV FIR TEQ using the BEM. In

other words, we design the TV FIR TEQ $w^{(r)}[n; \theta]$ to have $L' + 1$ taps, where the time variation of each tap is modeled by $Q' + 1$ time-varying complex exponential basis functions. Hence, we can write the TV FIR TEQ $w^{(r)}[n; \theta]$ for $n \in \{i(N+\nu) + \nu, \dots, (i+1)(N+\nu) - 1\}$ as:

$$w^{(r)}[n; \theta] = \sum_{l'=0}^{L'} \delta[\theta - l'] \sum_{q'=-Q'/2}^{Q'/2} w_{q',l'}^{(r)}[i] e^{j2\pi q'n/K}. \quad (5)$$

It is more convenient at this point to switch to a block level formulation. Defining $\mathbf{z}^{(r)}[i] = [z^{(r)}[i(N+\nu) + \nu - d], \dots, z^{(r)}[(i+1)(N+\nu) - d - 1]]^T$, $\mathbf{x}[i] = [x[i(N+\nu) + \nu - L' - L], \dots, x[(i+1)(N+\nu) - 1]]^T$ and $\boldsymbol{\eta}^{(r)}[i] = [\eta^{(r)}[i(N+\nu) - L'], \dots, \eta^{(r)}[(i+1)(N+\nu) - 1]]^T$, then (4) can be written on the block level as:

$$\mathbf{z}^{(r)}[i] = \sum_{l',q'} \sum_{l,q} w_{q',l'}^{(r)} h_{q,l}^{(r)} \mathbf{D}_{q'}[i] \mathbf{Z}_{l'} \tilde{\mathbf{D}}_q[i] \tilde{\mathbf{Z}}_l \mathbf{x}[i] + \sum_{l',q'} w_{q',l'}^{(r)} \mathbf{D}_{q'}[i] \mathbf{Z}_{l'} \boldsymbol{\eta}[i], \quad (6)$$

where $\mathbf{D}_{q'}[i] = \text{diag}\{e^{j2\pi q'(i(N+\nu) + \nu)/K}, \dots, e^{j2\pi q'((i+1)(N+\nu) - 1)/K}\}^T$, $\mathbf{Z}_{l'} = [\mathbf{0}_{N \times (L'-l')}, \mathbf{I}_N, \mathbf{0}_{N \times l'}]$, $\tilde{\mathbf{D}}_q[i] = \text{diag}\{e^{j2\pi q(i(N+\nu) + \nu - L')/K}, \dots, e^{j2\pi q((i+1)(N+\nu) - 1)/K}\}^T$, and $\tilde{\mathbf{Z}}_l = [\mathbf{0}_{(N+L') \times (L-l)}, \mathbf{I}_{N+L'}, \mathbf{0}_{(N+L') \times l}]$. Using the property $\mathbf{Z}_{l'} \tilde{\mathbf{D}}_q[i] = e^{j2\pi q l'/K} \mathbf{D}_{q'}[i] \mathbf{Z}_{l'}$, and defining $p = q + q'$ and $k = l + l'$, we can write (6) as:

$$\mathbf{z}[i] = \sum_{p=-(Q+Q')/2}^{(Q+Q')/2} \sum_{k=0}^{L+L'} f_{p,k}[i] \mathbf{D}_p[i] \tilde{\mathbf{Z}}_k \mathbf{x}[i] + \sum_{r=1}^{N_r} \sum_{l'=0}^{L'} \sum_{q'=-Q'/2}^{Q'/2} w_{q',l'}^{(r)}[i] \mathbf{D}_{q'}[i] \mathbf{Z}_{l'} \boldsymbol{\eta}[i], \quad (7)$$

where $\mathbf{z}[i] = \sum_{r=1}^{N_r} \mathbf{z}^{(r)}[i]$ and $\tilde{\mathbf{Z}}_k = [\mathbf{0}_{N \times (L+L'-k)}, \mathbf{I}_N, \mathbf{0}_{N \times k}]$. The 2-D function $f_{p,k}[i]$ can be written as:

$$f_{p,k}[i] = \sum_{r=1}^{N_r} \sum_{q'=-Q'/2}^{Q'/2} \sum_{l'=0}^{L'} e^{j2\pi(p-q')l'/K} w_{q',l'}^{(r)}[i] h_{p-q',k-l'}^{(r)}[i]. \quad (8)$$

Defining $\mathbf{f}[i] = [f_{-Q/2-Q'/2,0}[i], \dots, f_{Q/2+Q'/2,L+L'}[i]]^T$, we can further write (7) as:

$$\mathbf{z}[i] = (\mathbf{f}^T[i] \otimes \mathbf{I}_N) \mathbf{A} \mathbf{x}[i] + \sum_{r=1}^{N_r} (\mathbf{w}^{(r)T}[i] \otimes \mathbf{I}_N) \mathbf{B} \boldsymbol{\eta}^{(r)}[i] = (\mathbf{f}^T[i] \otimes \mathbf{I}_N) \mathbf{A} \mathbf{x}[i] + (\mathbf{w}^T[i] \otimes \mathbf{I}_N) (\mathbf{I}_{N_r} \otimes \mathbf{B}) \boldsymbol{\eta}[i] \quad (9)$$

where $\mathbf{w}^{(r)}[i] = [w_{-Q'/2,0}^{(r)}[i], \dots, w_{-Q'/2,L'}^{(r)}[i]]^T$, $\mathbf{w}[i] = [\mathbf{w}^{(1)T}[i], \dots, \mathbf{w}^{(N_r)T}[i]]^T$, $\boldsymbol{\eta}[i] = [\boldsymbol{\eta}^{(1)T}[i], \dots, \boldsymbol{\eta}^{(N_r)T}[i]]^T$, and \mathbf{A} and \mathbf{B} are give by:

$$\mathbf{A} = \begin{bmatrix} \mathbf{D}_{-Q/2-Q'/2} \tilde{\mathbf{Z}}_0 \\ \vdots \\ \mathbf{D}_{-Q/2-Q'/2} \tilde{\mathbf{Z}}_{L+L'} \\ \vdots \\ \mathbf{D}_{Q/2+Q'/2} \tilde{\mathbf{Z}}_{L+L'} \end{bmatrix}, \quad \mathbf{B} = \begin{bmatrix} \mathbf{D}_{-Q'/2} \mathbf{Z}_0 \\ \vdots \\ \mathbf{D}_{-Q'/2} \mathbf{Z}_{L'} \\ \vdots \\ \mathbf{D}_{Q'/2} \mathbf{Z}_{L'} \end{bmatrix},$$

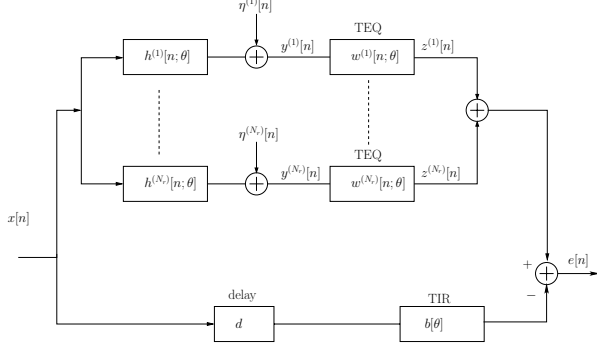

Fig. 1. TEQ equivalent figure

Note that the term in $f_{p,k}[i]$ corresponding to the r th receive antenna is related to a 2-dimensional convolution of the BEM coefficients of the doubly-selective channel for the r th receive antenna and the BEM coefficients of the TV FIR TEQ for the r th receive antenna. This allows us to derive a linear relationship between $\mathbf{f}[i]$ and $\mathbf{w}[i]$ as [9]:

$$\mathbf{f}^T[i] = \mathbf{w}^T[i] \mathcal{H}[i]. \quad (10)$$

The purpose of the TEQ is to convert the doubly-selective channel into a frequency-selective channel with order less than or equal to the length of the CP. The resulting shortened filter is called target-impulse response (TIR) denoted by $b[\theta]$ of order $L'' \leq \nu$:

$$b[\theta] = \sum_{l''=0}^{L''} \delta[\theta - l''] b_{l''}[i].$$

As shown in Figure 1, we require to design a TEQ $\mathbf{w}[i]$, a TIR $\mathbf{b}[i] = [b_0[i], \dots, b_{L''}[i]]^T$ and a synchronization delay d in order to minimize the difference between the upper branch and the lower branch. Defining $\mathbf{e}[i] = [e[i(N+\nu)], \dots, e[i(N+\nu) + N - 1]]^T$, we can express $\mathbf{e}[i]$ as:

$$\mathbf{e}[i] = (\mathbf{f}^T[i] \otimes \mathbf{I}_N) \mathbf{A} \mathbf{x}[i] + (\mathbf{w}^T[i] \otimes \mathbf{I}_N) (\mathbf{I}_{N_r} \otimes \mathbf{B}) \boldsymbol{\eta}[i] - (\tilde{\mathbf{b}}[i] \otimes \mathbf{I}_N) \mathbf{A} \mathbf{x}[i] \quad (11)$$

where the augmented vector $\tilde{\mathbf{b}}[i]$ can be written as $\tilde{\mathbf{b}}[i] = \mathbf{C} \mathbf{b}[i]$, with the selection matrix \mathbf{C} given by:

$$\mathbf{C} = \begin{bmatrix} \mathbf{0}_{((Q+Q')(L+L'+1)/2+d) \times (L''+1)} \\ \mathbf{I}_{L''+1} \\ \mathbf{0}_{((Q+Q')(L+L'+1)/2-L''-d-1) \times (L''+1)} \end{bmatrix}.$$

Hence, we can write the following cost function:

$$\begin{aligned} \mathcal{J} &= \mathcal{E} \left\{ \mathbf{e}^H[i] \mathbf{e}[i] \right\} \\ &= \text{tr} \left\{ (\mathbf{f}^T[i] \otimes \mathbf{I}_N) \mathbf{A} \mathbf{R}_x \mathbf{A}^H (\mathbf{f}^* [i] \otimes \mathbf{I}_N) \right\} \\ &+ \text{tr} \left\{ (\mathbf{w}^T[i] \otimes \mathbf{I}_N) (\mathbf{I}_{N_r} \otimes \mathbf{B}) \mathbf{R}_\eta (\mathbf{I}_{N_r} \otimes \mathbf{B}^H) (\mathbf{w}^* [i] \otimes \mathbf{I}_N) \right\} \\ &+ \text{tr} \left\{ (\tilde{\mathbf{b}}^T[i] \otimes \mathbf{I}_N) \mathbf{A} \mathbf{R}_x \mathbf{A}^H (\tilde{\mathbf{b}}^* [i] \otimes \mathbf{I}_N) \right\} \\ &- 2 \text{tr} \left\{ \Re \left\{ (\mathbf{f}^T[i] \otimes \mathbf{I}_N) \mathbf{A} \mathbf{R}_x \mathbf{A}^H (\tilde{\mathbf{b}}^* [i] \otimes \mathbf{I}_N) \right\} \right\} \quad (12) \end{aligned}$$

Let us now introduce the following properties:

$$\begin{aligned} \text{tr} \{ (\mathbf{x}^T \otimes \mathbf{I}_N) \mathbf{X} \} &= \mathbf{x}^T \text{subtr} \{ \mathbf{X} \}, \\ \text{tr} \{ (\mathbf{x}^T \otimes \mathbf{I}_N) \mathbf{X} (\mathbf{x}^* \otimes \mathbf{I}_N) \} &= \mathbf{x}^T \text{subtr} \{ \mathbf{X} \} \mathbf{x}^*, \end{aligned}$$

Table 1. Constraints of the TEQ

<p>1. $\ \mathbf{b}[i]\ ^2 = 1$ Unit norm constraint</p> $\mathbf{w}^T[i] = \tilde{\mathbf{b}}^T[i] \left(\mathcal{H}^H[i] \mathbf{R}_{\tilde{\mathbf{B}}}^{-1} \mathcal{H}[i] + \mathbf{R}_{\tilde{\mathbf{A}}}^{-1} \right)^{-1} \mathcal{H}^H[i] \mathbf{R}_{\tilde{\mathbf{B}}}^{-1}$ $\mathbf{b}^T[i] = \text{eig}_{\min}^a(\mathbf{R}^\perp)$ $\mathbf{R}^\perp = \mathbf{C}^T \left(\mathcal{H}^H[i] \mathbf{R}_{\tilde{\mathbf{B}}}^{-1} \mathcal{H}[i] + \mathbf{R}_{\tilde{\mathbf{A}}}^{-1} \right)^{-1} \mathbf{C}$
<p>2. $\mathbf{b}^H[i] \mathbf{R}_{\tilde{\mathbf{A}}} \mathbf{b}[i] = 1$ Unit energy constraint</p> $\mathbf{w}^T[i] = \tilde{\mathbf{b}}^T[i] \left(\mathcal{H}^H[i] \mathbf{R}_{\tilde{\mathbf{B}}}^{-1} \mathcal{H}[i] + \mathbf{R}_{\tilde{\mathbf{A}}}^{-1} \right)^{-1} \mathcal{H}^H[i] \mathbf{R}_{\tilde{\mathbf{B}}}^{-1}$ $\mathbf{b}^T[i] = \text{eig}_{\max}^a(\tilde{\mathbf{R}}^\perp)$ $\tilde{\mathbf{R}}^\perp = \mathbf{C}^T \left(\mathcal{H}^H[i] \mathbf{R}_{\tilde{\mathbf{B}}}^{-1} \mathcal{H}[i] + \mathbf{R}_{\tilde{\mathbf{A}}}^{-1} \right)^{-1} \mathcal{H}^H \mathbf{R}_{\tilde{\mathbf{B}}}^{-1} \mathcal{H} \mathbf{R}_{\tilde{\mathbf{A}}} \mathbf{C}$

^a $\text{eig}_{\min}(\mathbf{A})$ ($\text{eig}_{\max}(\mathbf{A})$) is the eigenvector corresponding to the minimum (maximum) eigenvalue of matrix \mathbf{A} .

where $\text{subtr}\{\cdot\}$ splits the matrix into $N \times N$ submatrices and replaces each submatrix by its trace. $\text{subtr}\{\cdot\}$ reduces the row and column dimension by a factor N . Hence, the cost function in (12) reduces to:

$$\begin{aligned} \mathcal{J} &= \mathbf{w}^T[i] \left(\mathcal{H}[i] \mathbf{R}_{\tilde{\mathbf{A}}} \mathcal{H}^H[i] + \mathbf{R}_{\tilde{\mathbf{B}}} \right) \mathbf{w}^*[i] + \tilde{\mathbf{b}}^T[i] \mathbf{R}_{\tilde{\mathbf{B}}} \tilde{\mathbf{b}}^*[i] \\ &- 2 \Re \{ \mathbf{w}^T[i] \mathcal{H}[i] \mathbf{R}_{\tilde{\mathbf{A}}} \tilde{\mathbf{b}}^*[i] \}, \quad (13) \end{aligned}$$

where $\mathbf{R}_{\tilde{\mathbf{A}}} = \text{subtr}\{\mathbf{A} \mathbf{R}_x \mathbf{A}^H\}$, and $\mathbf{R}_{\tilde{\mathbf{B}}} = \text{subtr}\{\mathbf{I}_{N_r} \otimes \mathbf{B}\} \mathbf{R}_v (\mathbf{I}_{N_r} \otimes \mathbf{B}^H)$. In order to avoid the trivial solution (zero vector $\mathbf{w}[i]$ and zero vector $\mathbf{b}[i]$) when minimizing the cost function in (13), a non-triviality constraint needs to be added. e.g., a unit tap constraint, $b_0[i] = 1$; a unit-norm constraint, $\|\mathbf{b}[i]\|^2 = 1$ or $\|\mathbf{g}[i]\|^2 = 1$; or a unit-energy constraint, $\mathbf{b}^H[i] \mathbf{R}_{\tilde{\mathbf{A}}} \mathbf{b}[i] = 1$ or $\mathbf{g}^H[i] \mathbf{R}_{\tilde{\mathbf{B}}} \mathbf{g}[i] = 1$. More details about these constraints for TI channels can be found in [6] for the unit-tap and unit-norm constraints, and in [10] for the unit-energy constraint. In Table 1 we show the different constraints and the corresponding solutions.

4. FREQUENCY-DOMAIN EQUALIZATION

Define $\hat{S}_k[i]$ as the estimate of the transmitted QAM symbol on the k th subcarrier of the i th OFDM block. This estimate is obtained by applying a 1-tap FEQ to the TEQ output after the FFT-demodulation:

$$\hat{S}_k[i] = \frac{1}{d_k[i]} \sum_{r=1}^{N_r} \sum_{q'=-Q'/2}^{Q'/2} \mathcal{F}^{(k)} \mathbf{D}_{q'}[i] \mathbf{W}_{q'}^{(r)}[i] \mathbf{y}^{(r)}[i] \quad (14)$$

where $\mathcal{F}^{(k)}$ is the $(k+1)$ st row of the FFT matrix \mathcal{F} , $\mathbf{W}_{q'}^{(r)}[i]$ is an $N \times (N+L')$ Toeplitz matrix, with the first column $[w_{q',L'}^{(r)}[i], \mathbf{0}_{1 \times (N-1)}]^T$ and first row $[w_{q',L'}^{(r)}[i], \dots, w_{q',0}^{(r)}[i], \mathbf{0}_{1 \times (N-L'-1)}]$ and $d_k[i]$ is the frequency response of the TIR on the k th subcarrier of the i th OFDM block ($1/d_k[i]$ represents the 1-tap FEQ).

The proposed TEQ optimizes the performance on all subcarriers in a joint fashion. An optimal full frequency-domain equalizer (FFEQ) that optimizes the performance on each subcarrier separately can then be obtained by transferring the TEQ operations to the frequency-domain. The obtained FFEQ is similar to the per-tone equalizer obtained in [11]. Hence the estimate of the transmitted QAM symbol on the k th subcarrier of the i th OFDM block

is obtained as:

$$\hat{S}_k[i] = \sum_{r=1}^{N_r} \sum_{q'=-Q'/2}^{Q'/2} \mathcal{F}^{(k)} \underbrace{\mathbf{D}_{q'}[i] \mathbf{Y}^{(r)}[i]}_{\tilde{\mathbf{Y}}_{q'}^{(r)}[i]} \underbrace{\mathbf{w}_{q'}^{(r)}[i]/d_k[i]}_{\tilde{\mathbf{w}}_{q'}^{(r,k)}[i]} \quad (15)$$

where $\mathbf{Y}^{(r)}[i]$ is an $N \times (L' + 1)$ Toeplitz matrix, with the first column $[y^{(r)}[i(N + \nu) + \nu], \dots, y^{(r)}[(i + 1)(N + \nu) - 1]]^T$ and first row $[y^{(r)}[i(N + \nu) + \nu], \dots, y^{(r)}[i(N + \nu) + \nu - L']]$ and $\tilde{\mathbf{w}}_{q'}^{(r,k)}[i]$ is the FEQ operating on the k th subcarrier of the q' th modulated version of the received sequence. Note here, that we can optimize the FEQ on each subcarrier separately without taking into account the specific relationship between the TEQ coefficients $\mathbf{w}_{q'}^{(r)}[i]$ and the 1-tap FEQ $d_k[i]$. The analysis and efficient implementation of this FEQ is discussed in more details in [12]. However, the complexity associated with the FFEQ is much higher than the complexity associated with the TEQ.

5. SIMULATIONS

In this section, we show some simulation results for the proposed TEQ. We consider a SISO as well as a SIMO system with $N_r = 2$. The channel is assumed to be doubly-selective of order $L = 6$ and a maximum Doppler spread $f_{\max} = 100\text{Hz}$. The channel taps are simulated as i.i.d., correlated in time with a correlation function according to Jakes' model $\mathcal{E}\{h(n_1; l_1)h^*(n_2; l_2)\} = \sigma_h^2 J_0(2\pi f_{\max} T(n_1 - n_2))\delta(l_1 - l_2)$, where J_0 is the zeroth-order Bessel function of the first kind, T is the sampling time, and σ_h^2 denotes the variance of the channel. We consider $N = 128$ subcarriers, and a CP of length $\nu = 3$. The sampling time is $T = 50\mu\text{sec}$, the total OFDM symbol duration is 6.6msec . QPSK signaling is assumed. We define the signal-to-noise ratio (SNR) as $\text{SNR} = \sigma_h^2(L + 1)E_s/\sigma_n^2$, where E_s is the QPSK symbol power.

We use the BEM to approximate the channel. The channel BEM resolution is determined by $K = 2N$. The number of complex exponentials is then determined by $Q = 4$. The BEM coefficients of the approximated channel are used to design the TEQ (unit-norm constraint (UNC) and the unit-energy constraint (UEC)) and the FFEQ. We consider $Q' = 14$ and $L' = 14$ for $N_r = 1$ and $Q' = 8$ and $L' = 8$ for $N_r = 2$. The delay d is always chosen as $d = \lfloor (L + L')/2 \rfloor + 1$. The proposed TEQ in conjunction with the 1-tap FEQ denoted by MTFEQ (mixed time- and frequency-domain equalizer) and FFEQ are used to equalize the true Jakes' channel. The performance is measured in terms of BER vs. SNR. As shown in figure 2, the performance of the MTFEQ considering the UNC coincides with the performance of the MTFEQ considering the UEC for both $N_r = 1$ and $N_r = 2$. However, the FFEQ significantly outperforms the MTFEQ for both $N_r = 1$ and $N_r = 2$, where the latter suffers from an early error floor. This performance gain comes at the cost of a higher complexity of the FFEQ on the TEQ (design complexity and run-time complexity).

6. REFERENCES

- [1] Y.-S. Choi, P. J. Voltz and F. A. Cassara, "On Channel Estimation and Detection for Multicarrier Signals in Fast and Selective Rayleigh Fading Channels," *IEEE Trans. Commun.*, vol. 49, pp. 1375–1387, Aug. 2001.
- [2] W. G. Jeon, K. H. Chang and Y. S. Cho, "An Equalization Technique for Orthogonal Frequency Division Multiplexing

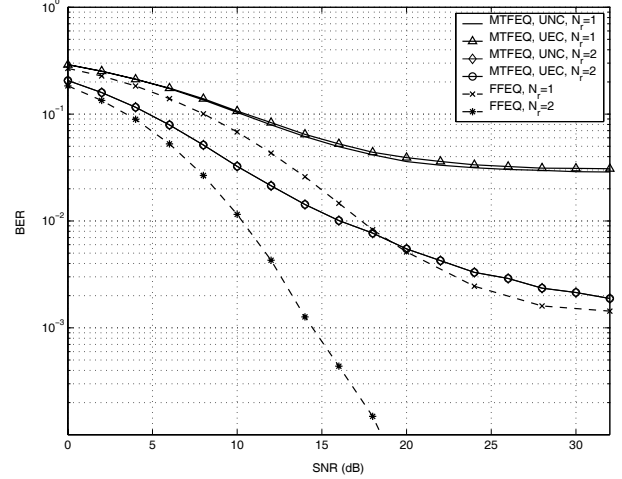

Fig. 2. BER vs. SNR for MTFEQ and FFEQ for $N_r = 1, 2$

Systems in Time-Variant Multipath Channels," *IEEE Trans. Commun.*, vol. 47, pp. 27–32, Jan. 1999.

- [3] X. Cai and G. B. Giannakis, "Low-Complexity ICI Suppression for OFDM over Time- and Frequency-Selective Rayleigh Fading Channels," in *Proc. of 36th Asilomar Conf. on Signals, Systems, and Computers*, (Pacific Grove, CA), pp. 1822–1826, Nov. 2002.
- [4] A. Stamoulis, S. N. Diggavi and N. Al-Dhahir, "Intercarrier Interference in MIMO OFDM," *IEEE Trans. Signal Processing*, vol. 50, Oct. 2002.
- [5] P. Schniter and S. D'silva, "Low-Complexity Detection of OFDM in Doubly-Dispersive channels," in *Proc. Asilomar Conf. on Signals, Systems, and Computers*, (Pacific Grove, CA), Nov. 2002.
- [6] N. Al-Dhahir and J. M. Cioffi, "Optimum Finite-Length Equalization for Multicarrier Transceivers," *IEEE Trans. Signal Processing*, vol. 44, pp. 56–64, Jan. 1996.
- [7] G. B. Giannakis and C. Tepedelenlioglu, "Basis Expansion Models and Diversity Techniques for Blind Identification and Equalization of Time Varying Channels," *Proc. IEEE*, vol. 86, no. 10, pp. 1969–1986, Oct., 1998.
- [8] G. Leus, S. Zhou and G. B. Giannakis, "Orthogonal Multiple Access over Time- and Frequency-Selective Fading," *IEEE Trans. Inform. Theory*, vol. 49, pp. 1942–1950, Aug. 2003.
- [9] I. Barhumi, G. Leus and M. Moonen, "Time Varying FIR Equalization of Doubly-Selective Channels," *IEEE Trans. Wireless Commun.*, Oct. 2003. (accepted).
- [10] G. Ysebaert, K. Van Acker, M. Moonen and B. De Moor, "Constraints in Channel Shortening Equalizer Design for DMT-based Systems," *Elsevier Signal Processing*, vol. 83, pp. 641–648, Mar. 2003.
- [11] K. van Acker, G. Leus, M. Moonen, O. van de Wiel and T. Pollet, "Per-tone Equalization for DMT-based Systems," *IEEE Trans. Commun.*, vol. 49, Jan. 2001.
- [12] I. Barhumi, G. Leus and M. Moonen, "Per-Tone Equalization for OFDM over Doubly-Selective Channels," in *IEEE Int. Conf. on Communications*, (Paris, France), June 2004. (submitted).