

EE2S11 SIGNALS AND SYSTEMS

Part 2 exam, 30 January 2024, 13:30–15:30

Closed book; one A4 (two sides) of handwritten notes permitted. No other tools except a basic pocket calculator permitted.

This exam consists of five questions (36 points). Answer in Dutch or English. Make clear in your answer how you reach the final result; the road to the answer is very important.

Question 1 (10 points)

- a) Given the signals $x[n] = u[n + 2] - u[n - 2]$, $h[n] = [\dots, 0, \boxed{1}, -2, 0, 0, \dots]$.

Determine $y[n] = x[n] * h[n]$ using the convolution sum (in time-domain).

- b) Given $x[n] = u[n] - (\frac{1}{2})^n u[n - 4]$. Determine $X(z)$ and also specify the ROC.
 c) Given $x[n] = a^n u[n]$ with $|a| < 1$. Determine $y[n] = x[n] * x[-n]$. (Use the z -transform.)
 d) Determine, if it exists, the frequency response $H(e^{j\omega})$ for the system defined by the difference equation

$$y[n] = 1.6y[n - 1] - 0.64y[n - 2] + x[n] - x[n - 2]$$

- e) Given an LTI system with transfer function $H(z) = 1 - 2z^{-1}$.

Determine a (bounded) input signal $x[n]$ for which the output signal is equal to $y[n] = \delta[n] + \frac{1}{2}\delta[n - 1]$.

Solution

a)
$$y[n] = \sum_k h[k]x[n - k]$$

$$\begin{array}{rcccccccc} h[0]x[n] : & \dots & 0 & 1 & 1 & \boxed{1} & 1 & 0 & 0 & 0 & \dots \\ h[1]x[n-1] : & \dots & 0 & 0 & -2 & \boxed{-2} & -2 & -2 & 0 & 0 & \dots \\ \hline y[n] : & \dots & 0 & 1 & -1 & \boxed{-1} & -1 & -2 & 0 & 0 & \dots \end{array}$$

- b)

$$x[n] = u[n] - \left(\frac{1}{2}\right)^4 \left(\frac{1}{2}\right)^{n-4} u[n - 4]$$

$$X(z) = \frac{1}{1 - z^{-1}} - \frac{\left(\frac{1}{2}\right)^4 z^{-4}}{1 - \frac{1}{2}z^{-1}}$$

ROC: $\{|z| > 1\}$

- c)

$$x[n] = a^n u[n] \quad \rightarrow \quad X(z) = \frac{1}{1 - az^{-1}} \quad \text{ROC: } \{|z| > a\}$$

$$x[-n] = a^{-n} u[-n] \quad \rightarrow \quad X(z^{-1}) = \frac{1}{1 - az} \quad \text{ROC: } \{|z| < 1/a\}$$

Result of the convolution in z -domain is a product:

$$Y(z) = \frac{1}{1 - az^{-1}} \cdot \frac{1}{1 - az} \quad \text{ROC: } \{a < |z| < 1/a\}$$

To recover $y[n]$, we need to apply a partial fraction expansion, therefore we first write the function using polynomials in z or z^{-1} (but not both). Hence:

$$Y(z) = \frac{z}{(z - a)(1 - az)} = \frac{A}{z - a} + \frac{B}{1 - az} = \dots = \frac{1}{1 - a^2} \left(\frac{a}{z - a} + \frac{1}{1 - az} \right)$$

Check the ROC to determine which part is causal and which part is anti-causal. The first term (with ROC: $\{|z| > a\}$) is causal and therefore we write it in terms of z^{-1} . The second term (with ROC: $\{|z| < 1/a\}$) is anti-causal and we keep it in terms of z . This results in:

$$Y(z) = \frac{1}{1 - a^2} \left(\frac{az^{-1}}{1 - az^{-1}} + \frac{1}{1 - az} \right) = \frac{1}{1 - a^2} \left(\frac{1}{1 - az^{-1}} - 1 + \frac{1}{1 - az} \right)$$

$$y[n] = \frac{1}{1 - a^2} (a^n u[n] - 1 + a^{-n} u[-n]) = \frac{a^{|n|}}{1 - a^2}$$

d) First apply a z -transform:

$$Y(z)(1 - 1.6z^{-1} + 0.64z^{-2}) = X(z)(1 - z^{-2})$$

$$H(z) = \frac{1 - z^{-2}}{1 - 1.6z^{-1} + 0.64z^{-2}} = \frac{1 - z^{-2}}{(1 - 0.8z^{-1})^2} \quad \text{ROC: } |z| > 0.8$$

The poles are $z_{1,2} = 0.8$ (double), the unit circle is in the ROC and the Fourier transform exists. This results in

$$H(e^{j\omega}) = \frac{1 - e^{-2j\omega}}{(1 - 0.8e^{-j\omega})^2}$$

e)

$$Y(z) = 1 + \frac{1}{2}z^{-1}$$

$$X(z) = \frac{Y(z)}{H(z)} = \frac{1 + \frac{1}{2}z^{-1}}{1 - 2z^{-1}}$$

Because we require a bounded $x[n]$, the ROC is $\{|z| < 2\}$ which gives an anti-causal sequence. Therefore we rewrite $X(z)$ as

$$X(z) = \frac{z(1 + \frac{1}{2}z^{-1})}{z - 2} = -\frac{1}{2} \frac{\frac{1}{2} + z}{1 - \frac{1}{2}z} = -\frac{1}{2} \left(\frac{1}{2} + \frac{5}{4} \frac{z}{1 - \frac{1}{2}z} \right)$$

$$x[n] = -\frac{1}{2} \left(\frac{1}{2} \delta[n] + \frac{5}{4} \left(\frac{1}{2} \right)^{-n-1} u[-n - 1] \right) = -\frac{1}{4} \delta[n] + \frac{5}{8} \left(\frac{1}{2} \right)^{-n-1} u[-n - 1]$$

(This could be written in several equivalent ways, depending on how you rewrite $X(z)$.)

Question 2 (6 points)

The transfer function of a causal LTI system is given by $H(z) = \frac{z - 1}{z(z + 0.9)}$

- Determine all poles and zeros of the system and make a drawing in the complex z -plane.
- Specify the ROC.
- Is the system BIBO stable? (Why?)
- Draw, based on the poles and zeros of $H(z)$, the amplitude response. Is this a low-pass, high-pass or other kind of filter?

Solution

a) Poles: $z = 0, z = -0.9$. Zeros: $z = 1, z = \infty$.

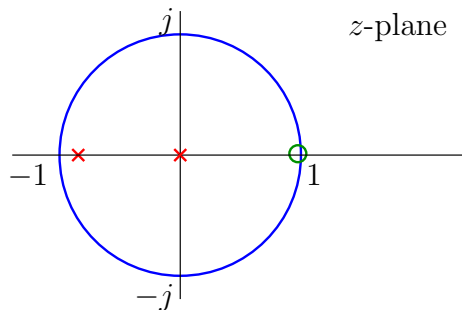

b) Causal results in ROC: $|z| > 0.9$.

c) Unit circle in ROC: BIBO stable.

d)

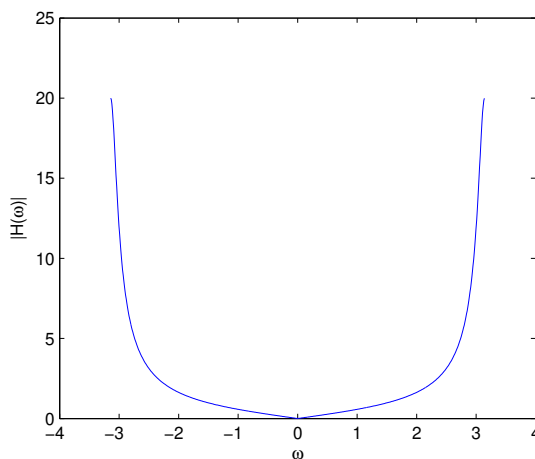

High-pass. Zero at $z = 1$ results in $H(e^{j\omega}) = 0$ for $\omega = 0$. The pole at $z = -0.9$ results in a peak for $\omega = \pm\pi$. The pole at $z = 0$ only has an effect on the phase. Compute: $H(e^{j\pi}) = H(1) = 20$. (However, the pole-zero plot does not specify the gain so this value is actually unknown.) The shown plot should be symmetric and either plot from $-\pi$ to π , or show periodicity outside this interval.

Question 3 (7 points)

An analog signal $x_a(t)$ with Fourier transform $X_a(\Omega)$ is band-limited at 10 kHz. The signal is sampled without aliasing at a sampling frequency F_s , resulting in the discrete-time signal $x[n]$. The spectrum $X(\omega)$ of $x[n]$ is shown below:

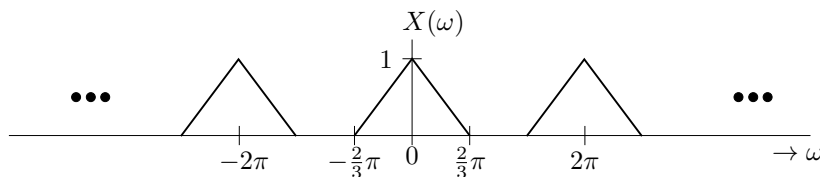

a) What is the relation between Ω and ω ?

- b) Which sampling frequency was used?
 c) What is the smallest frequency at which we can sample $x_a(t)$ without aliasing?

For this case, draw the resulting spectrum (also clearly mark the frequencies).

- d) Consider the initial sampling rate. After sampling, $x_a(t)$ is reconstructed from $x[n]$ by means of an ideal D/A convertor and a low-pass filter. Specify the pass-band and stop-band frequencies of the filter.

Solution

- a) $\omega = \Omega T_s$.

This standard result could be rederived if you recall that $\omega = 2\pi \leftrightarrow \Omega = 2\pi F_s$. This results in $\Omega = \omega F_s$ i.e., $\omega = \Omega T_s$.

- b) $\omega = \frac{2}{3}\pi$ results in $\Omega = \frac{2}{3}\pi F_s$. At $F = 10$ kHz we find

$$F = \frac{\Omega}{2\pi} = \frac{\frac{2}{3}\pi F_s}{2\pi} = \frac{1}{3}F_s = 10\text{kHz}$$

hence $F_s = 30$ kHz.

- c) $F_s = 20$ kHz.

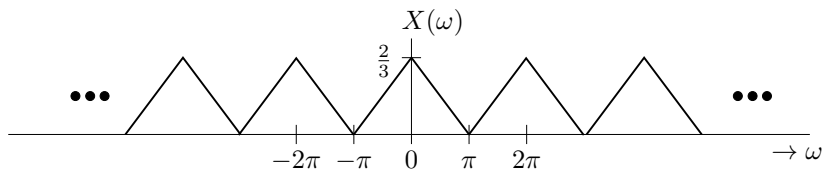

(To be accurate about the peak amplitude: Note that sampling at T_s will scale the amplitude by $1/T_s = F_s$, so if the initial figure was sampled at 30 kHz and the current one at 20 kHz, the peak amplitude will be $2/3$.)

- d) After D/A conversion, the signal is analog. In the frequency spectrum, the frequency $\omega_p = \frac{2}{3}\pi$ corresponds to $F_p = 10$ kHz, and the frequency $\omega_s = \frac{4}{3}\pi$ corresponds to $F_{stop} = 20$ kHz. The low-pass filter (in the analog domain! no periodicity) thus has a pass-band running until 10 kHz and a stop-band starting at 20 kHz.

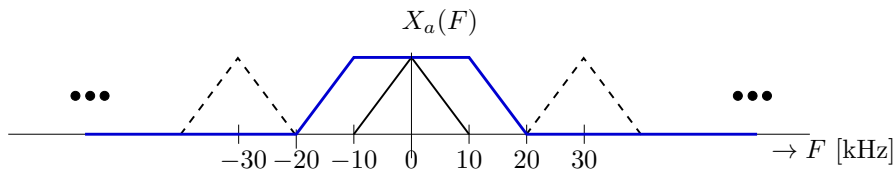

Question 4 (6 points)

Given the realizations:

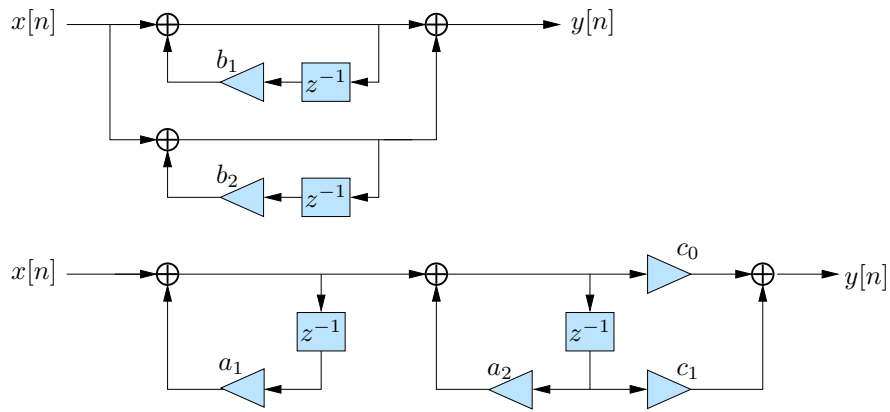

- Determine a_1 , a_2 and c_0 , c_1 in terms of b_1 , b_2 such that both systems are equivalent.
- Are these minimal realizations?
- Draw the “direct form no. II” realization and also specify the coefficients.

Solution

- First realization:

$$H(z) = \frac{1}{1 - b_1 z^{-1}} + \frac{1}{1 - b_2 z^{-1}} = \frac{2 - (b_1 + b_2)z^{-1}}{(1 - b_1 z^{-1})(1 - b_2 z^{-1})}$$

Second realization:

$$H(z) = \frac{1}{1 - a_1 z^{-1}} \cdot \frac{c_0 + c_1 z^{-1}}{1 - a_2 z^{-1}} = \frac{c_0 + c_1 z^{-1}}{(1 - a_1 z^{-1})(1 - a_2 z^{-1})}$$

From this it follows that $a_1 = b_1$, $a_2 = b_2$, $c_0 = 2$, $c_1 = -(b_1 + b_2)$.

- Both are minimal because the number of delays in the realization is equal to the filter order of $H(z)$.
-

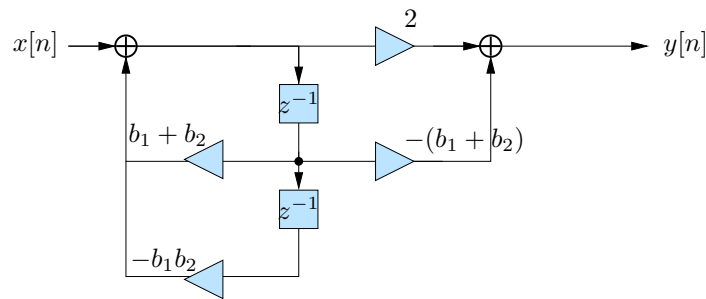

Question 5 (7 points)

A “template” third-order Butterworth filter has the transfer function

$$H(s) = \frac{1}{s^3 + 2s^2 + 2s + 1}$$

The corresponding frequency response is $|H(j\Omega)|^2 = \frac{1}{1 + \Omega^6}$.

- a) Which frequency transform should we apply to the template to construct a low-pass Butterworth filter with a 3dB cut-off frequency of Ω_c ?
- b) What is the corresponding transfer function $G(s)$?

We now design an analog 3rd order low-pass Butterworth filter with a pass-band frequency of 3 rad/s, a stop-band frequency of 6 rad/s and a maximal damping in the pass-band of 0.5 dB.

- c) Give a suitable expression for the frequency response (squared-amplitude) of this filter and determine its parameters.
- d) For this filter, what is the minimal damping in the stop-band ?
- e) Which transform should be applied to $|H(j\Omega)|^2$ to obtain this filter?
Determine the corresponding transfer function.

Solution

- a) Substitute $\Omega \rightarrow \frac{\Omega}{\Omega_c}$.
- b) Substitute $s \rightarrow \frac{s}{\Omega_c}$, this results in

$$G(s) = \frac{1}{\left(\frac{s}{\Omega_c}\right)^3 + 2\left(\frac{s}{\Omega_c}\right)^2 + 2\left(\frac{s}{\Omega_c}\right) + 1}$$

- c) The general expression is

$$|H(j\Omega)|^2 = \frac{1}{1 + \epsilon^2 \left(\frac{\Omega}{\Omega_p}\right)^6}$$

For $\Omega = \Omega_p = 3$ we obtain

$$\frac{1}{1 + \epsilon^2} = 10^{-0.5/10} \Rightarrow \epsilon = 0.3493$$

- d) For $\Omega = \Omega_s = 6$ we obtain

$$\frac{1}{1 + \epsilon^2 \left(\frac{6}{3}\right)^6} = 0.1135 \doteq -9.45 \text{ dB}$$

The stopband damping is 9.45 dB.

- e) First, we determine Ω_c :

$$\left(\frac{\Omega}{\Omega_c}\right)^6 = \epsilon^2 \left(\frac{\Omega}{\Omega_p}\right)^6 \Rightarrow \Omega_c = \frac{\Omega_p}{\epsilon^{1/3}} = 4.26 \text{ rad/s}$$

The transformation is $\Omega \rightarrow \frac{\Omega}{4.26} = 0.235\Omega$.

The transfer function of the requested Butterworth filter is:

$$H(s) = \frac{1}{\left(\frac{s}{4.26}\right)^3 + 2\left(\frac{s}{4.26}\right)^2 + 2\left(\frac{s}{4.26}\right) + 1}$$